

# E F N O T E 3



EFD3A-STDSET  
EFD3B-STDSET





## Quickstart Guide



EN

# Hello!

## Contents

<b>IMPORTANT SAFETY INSTRUCTIONS</b> . . . . .	3
Important Information . . . . .	4
<b>Assembling</b> . . . . .	5
Packing List . . . . .	5
Assembly . . . . .	6
Replacing the Beater Patch When It Becomes Worn . . . . .	9
Tuning the Head Tension . . . . .	9
<b>Connection</b> . . . . .	10
<b>Basic Operation</b> . . . . .	12
Panel Description . . . . .	12
Power On/Off . . . . .	12
Home Screen . . . . .	13
 Volume . . . . .	13
 Inst Info . . . . .	13
 Click (Metronome) . . . . .	13
 Recorder . . . . .	13
 Menu . . . . .	14
Power Menu . . . . .	14
Adjusting the Hi-Hat (Auto Calibration) . . . . .	15
Changing the Power Save Setting . . . . .	15
Connecting Your Smartphone with Bluetooth . . . . .	16
Changing the Instrument . . . . .	17
Adjusting the Pad Levels . . . . .	17
<b>Specifications</b> . . . . .	18
Optional components and consumable parts . . . . .	19
<b>Support</b> . . . . .	19

For the EFNOTE 3 Reference Guide or other latest information, please refer to the web below.

### Reference Guide PDF

[ef-note.com/products/drums/  
EFNOTE3A/efnote3.html#downloads](http://ef-note.com/products/drums/EFNOTE3A/efnote3.html#downloads)

### Product Information

[ef-note.com/products/drums/EFNOTE3A](http://ef-note.com/products/drums/EFNOTE3A)



Reference Guide





Product Info

# IMPORTANT SAFETY INSTRUCTIONS



FAILURE TO OBSERVE THE FOLLOWING SAFETY INSTRUCTIONS MAY RESULT IN FIRE, ELECTRIC SHOCK, INJURY TO PERSONS, OR DAMAGE TO OTHER ITEMS OR PROPERTY.

You must read and follow these instructions, heed all warnings, before using this product. Please keep this guide for future reference.

## About warnings and cautions

 <b>WARNING</b>	Indicates a hazard that could result in death or serious injury
 <b>CAUTION</b>	Indicates a hazard that could result in injury or property damage

## About the symbols

	"Caution": Calls your attention to a point of caution
	"Do not ...": Indicates a prohibited action
	"You must ...": Indicates a required action

### **WARNING**

To reduce the risk of fire or electric shock, do not expose this product to rain or moisture



**Do not use or store in the following locations**

- Locations subject to water or rain
- Moist or humid locations (near a bath or shower, or on a wet floor)
- High temperature locations (in direct sunlight, near heating equipment)
- Locations subject to salt damage
- Excessively dusty locations



**Turn the power off if an abnormality or accident occurs**

In the following situations, immediately turn off the power, disconnect the AC adapter from the AC outlet, and contact your dealer.



- If the AC adapter, power cord, or plug is damaged
- If smoke is emitted or an abnormal odor is noticed
- If liquid or a foreign object enters the product
- If an abnormality or malfunction occurs in the product



**Do not plug or unplug the AC adapter with wet hands**

You risk electric shock.



**Do not drop or subject to strong impact**

Do not drop this product or subject it to strong impact.



**Do not disassemble**

Do not disassemble or modify this product and AC adapter.



**Do not damage the power cord**

Do not excessively bend the power cord or damage it. Do not place heavy objects on top of the power cord. Doing so may damage the power cord, causing fire or electric shock.



**Use the included AC adapter**

Use only the included AC adapter. Use the adapter with the voltage that it specifies.

### **CAUTION**



**Do not place the product in an unstable location**

Doing so may cause the product to overturn, causing personal injury.



**Do not sit or stand on the product, or place heavy objects on it**

Doing so may damage the product. You should also avoid applying excessive force to the buttons, knobs, display, and input/output jacks. Doing so will cause malfunctions.



**Do not use the product at a high volume for an extended time**

Using speakers or headphones at high volume for an extended time will damage your hearing.



**Grasp the power plug when connecting or disconnecting**

When connecting or disconnecting the AC adapter from the product, you must grasp the plug rather than pulling the power cord.



**Disconnect the power plug from the AC outlet during lightning storms or when unused for long periods of time**

Failure to do so may cause electric shock, fire, or malfunction.



**Disconnect all connections before moving the product**

Failure to do so may cause damage to the power cord or cables, or may cause people to trip over the cables.



**Handle the product with care**

Take care that your hands or fingers are not injured by corners, edges or openings of the product.



**Keep small parts out of reach of children**

Keep small parts out of reach of children who might accidentally swallow them.



**Supervise or give guidance when children use this product or when children are present around this product**

Always take care that children are not injured with this product.

## Important Information

### Power supply

- A small amount of current flows even when the power is turned off. If you will not be using this product for an extended period of time, you may desire to unplug the AC adapter from the AC outlet.

### Regulatory compliance for radio emission devices

- You should keep turning the Bluetooth off when using the product in a country/region other than where it sold.
- The following actions may violate the law.
  - Disassembling or modifying this product.
  - Removing the certification label on the product.

### Placement

- Do not use this product near other electrical products such as televisions, radios. This product may cause noise in televisions or radios.

### Cleaning

- Use a soft dry cloth to clean the product. Do not use benzene, thinner, detergent, or chemically treated cloth, since these can cause deformation or discoloration.

### Data

- Please be aware that the manufacturer bears no responsibility for any consequences that may arise from damage to or loss of data.
- In some cases, equipment malfunction or incorrect operation can cause the contents of the memory to be lost. Please make a backup of any important data that is in the memory.

### Copyright

- Duplication or reuse of the music and sound data contained in or included with this product without permission from the copyright holder is forbidden (with the exception of copying for personal use as permitted by copyright law).
- Copyright for the content (sound data, phrase data, audio data, image data, computer programs, etc.) contained in or included with this product is the property of Ef-Note Inc. Copyright law forbids you to use the above content without permission of Ef-Note Inc. for any purpose other than personal use.
- The above content that is contained in or included with this product may not be resold, distributed, or published, neither in its existing form nor in any way that resembles it.

### Others

- Mac and macOS are trademarks of Apple Inc., registered in the U.S. and other countries.
- Windows is a trademark or registered trademark of Microsoft Corporation.
- ASIO is a trademark and software of Steinberg Media Technologies GmbH.
- The Bluetooth® word mark and logos are registered trademarks owned by Bluetooth SIG, Inc..
- Company names or product names etc. appearing in this document are the registered trademarks or trademarks of their respective corporate owners.
- EFNOTE is a trademark or registered trademark of Ef-Note Inc.
- All illustrations and screens appearing in this document are for the purpose of explaining operation, and may differ from the actual product or specifications.

\* Ef-Note Inc. cannot be held responsible for damage caused by improper use or modifications to the product, or loss of data.

### For EU countries, UK



Ef-Note Inc. hereby declares that the type of radio equipment EFNOTE 3 (EFD3A-STDSET, EFD3B-STDSET) complies with Directive 2014/53/EU.

The full text of the EU Declaration of Conformity is available at : [ef-note.com/compliance](http://ef-note.com/compliance)



This symbol on the product means that used electrical and electronic equipment should not be mixed with general household waste. The correct disposal will help prevent potential negative effects on human health and the environment. For proper treatment, recovery and recycling, please contact your city office, waste disposal servicer or the shop which you purchased the product.

### For the USA

#### WARNING

This product contains a chemical known to the State of California to cause cancer, birth defects or other reproductive harm.

#### FCC INFORMATION

This equipment has been tested and found to comply with the limits for a Class B digital device, pursuant to part 15 of the FCC Rules. These limits are designed to provide reasonable protection against harmful interference in a residential installation. This equipment generates, uses and can radiate radio frequency energy and, if not installed and used in accordance with the instructions, may cause harmful interference to radio communications. However, there is no guarantee that interference will not occur in a particular installation. If this equipment does cause harmful interference to radio or television reception, which can be determined by turning the equipment off and on, the user is encouraged to try to correct the interference by one or more of the following measures:

- Reorient or relocate the receiving antenna.
- Increase the separation between the equipment and receiver.
- Connect the equipment into an outlet on a circuit different from that to which the receiver is connected.
- Consult the dealer or an experienced radio/TV technician for help.

This device complies with part 15 of the FCC Rules. Operation is subject to the following two conditions:

- (1) This device may not cause harmful interference, and
- (2) this device must accept any interference received, including interference that may cause undesired operation.

## Assembling

## ■ Packing List

<b>A</b>	Sound Module	1x	<b>H</b>	16" Standard Cymbal	1x	<b>R</b>	Trigger Cable	4x
<b>B</b>	12" Kick Pad	1x	<b>K</b>	Smartphone Tray	1x	<b>S</b>	AC Adapter	1x
<b>C</b>	12" Snare Pad with Side-Rim	1x	<b>L</b>	Lambda Tripod	3x	<b>T</b>	Beater Patch	1x
<b>D</b>	10" Tom Pad	2x	<b>M</b>	Snare Stand	1x	<b>U</b>	Tuning Key	1x
<b>E</b>	12" Tom Pad	1x	<b>N</b>	Module Mount	1x		Cable Tie	10x
<b>F</b>	12" Hi-Hat Cymbals	1x	<b>P</b>	Multi-AX Cable	1x		Quickstart Guide	1x
<b>G</b>	14" Standard Cymbal	<b>STYLE A</b>	1x	<b>Q</b>	Multi-B Cable	1x		
		<b>STYLE B</b>	2x					

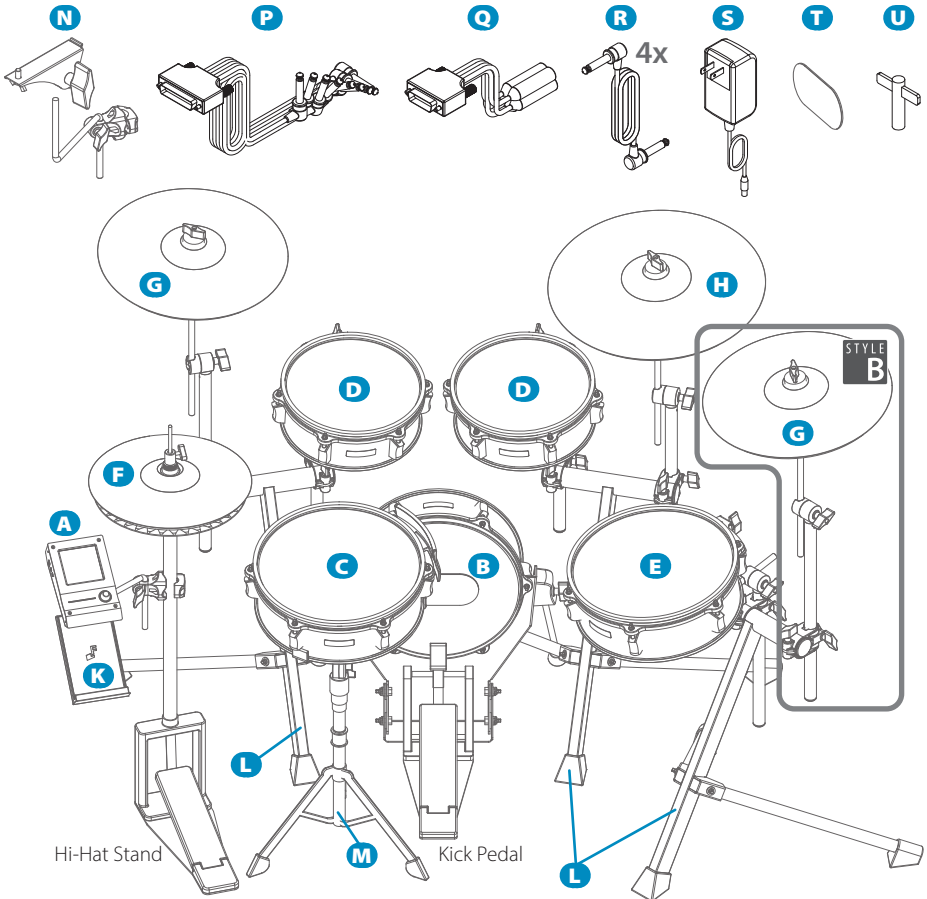

**NOTE** \* Kick pedal and hi-hat stand are optional, and may be included depending on the package purchased. For details, please contact the store where you purchased the product.

■ Assembly

**CAUTION** Please be careful not to injure yourself during assembly.

1

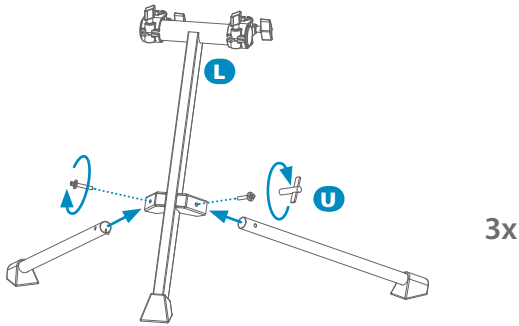

2

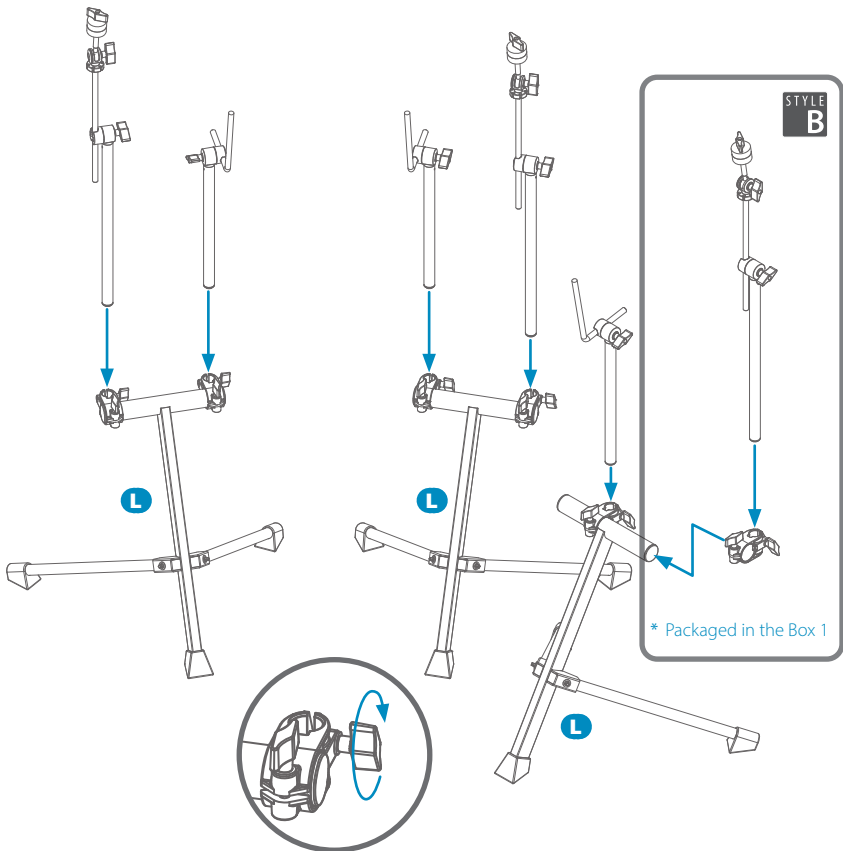

3

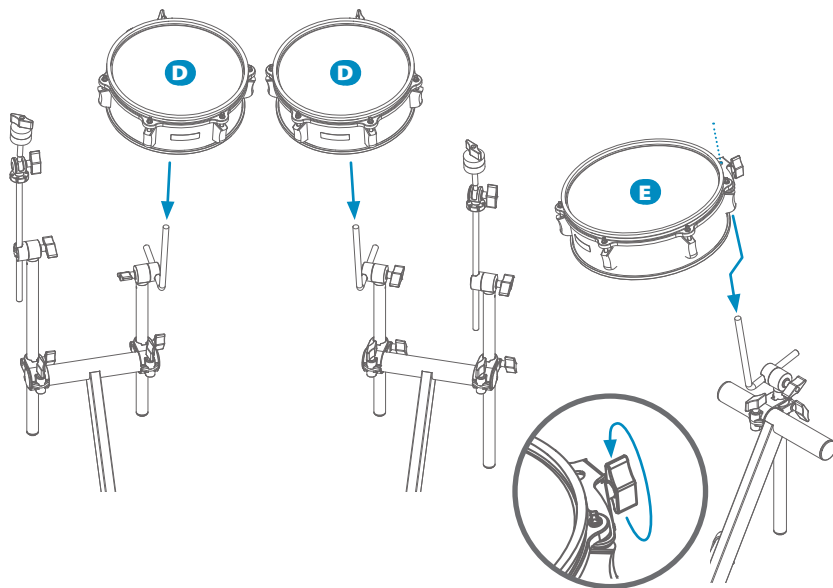

4

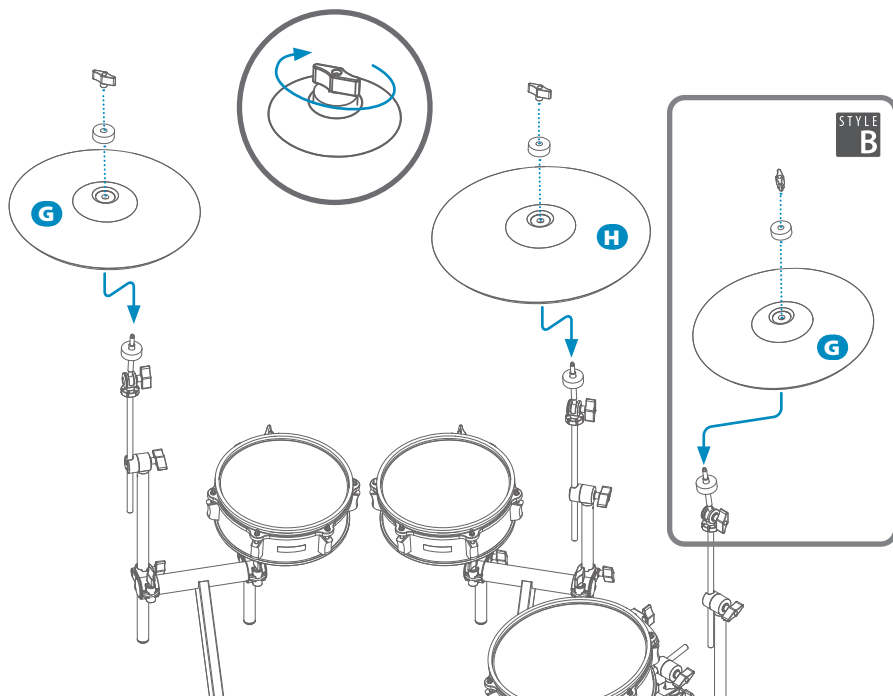

5

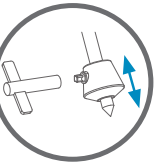
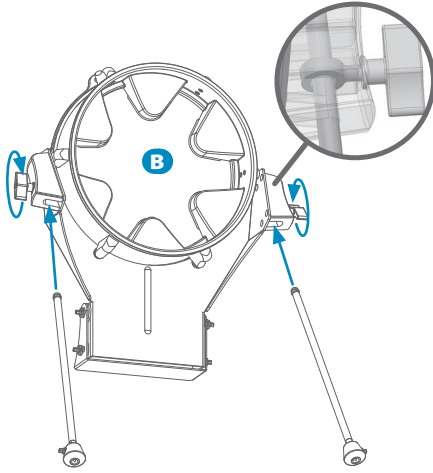

\* Be careful with the spikes

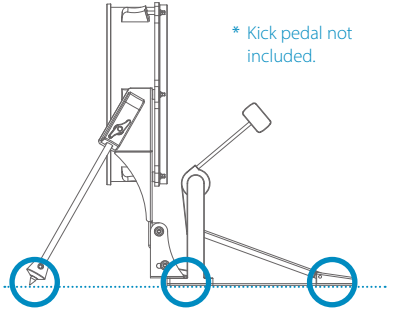

\* Make sure that the three points firmly make contact with the floor using the adjustments below.

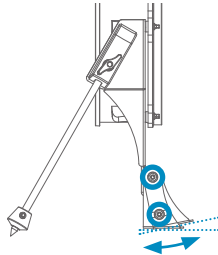

\* Adjust the angle of the base plate if your kick pedal is unstable. (Loosen four bolts to adjust.)

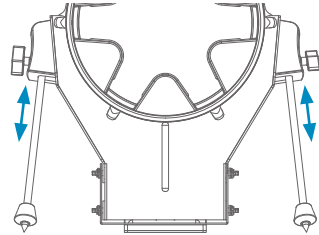

\* Adjust the length if the legs are unstable.

6

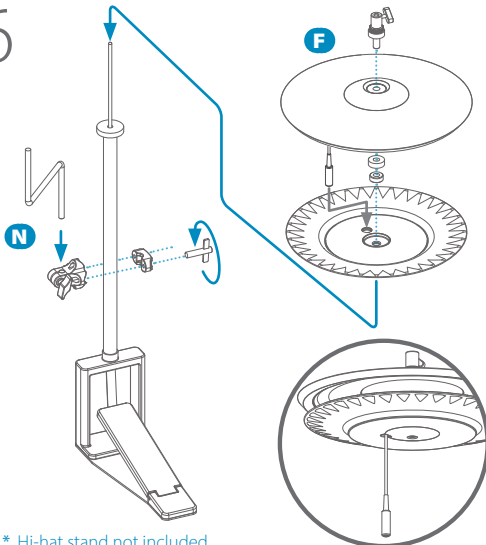

\* Hi-hat stand not included

7

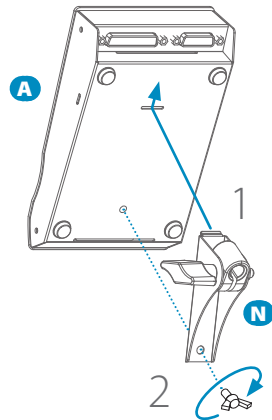

\* Be sure to use the included screws.



8

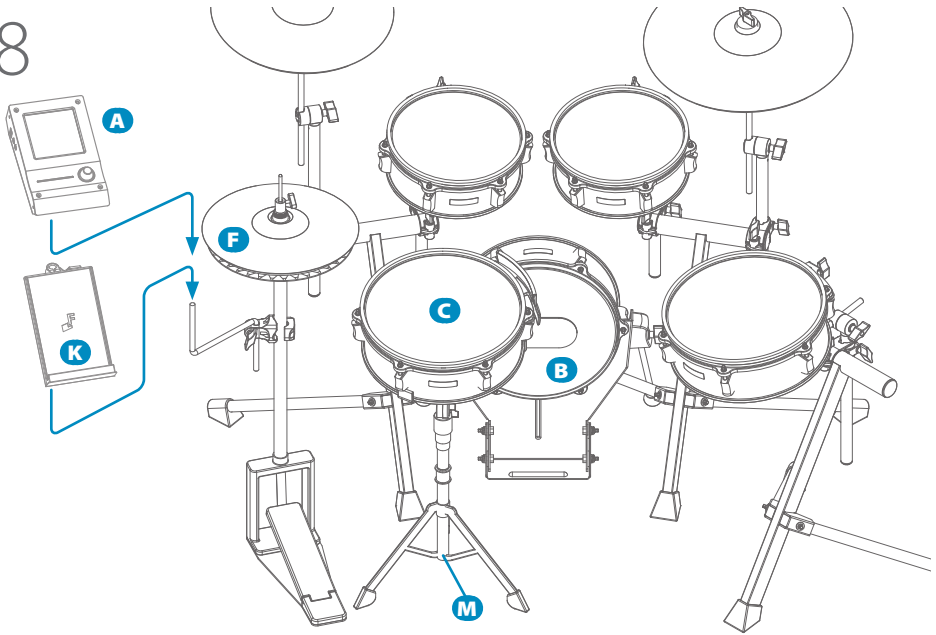

- \* Be sure to tighten all knobs and bolts firmly.
- \* Make sure that all stands are stable.
- \* Be careful that your smartphone does not fall from the smartphone tray.

## ■ Replacing the Beater Patch When It Becomes Worn

Replace the beater patch in its original position.

- \* Playing without the beater patch may cause damage to the head.
- \* Be sure not the hard edge of your beater touches the hitting surface.
- \* The beater patch is a consumable item. Replace when it has worn.

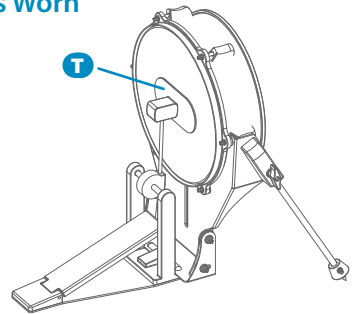

## ■ Tuning the Head Tension

Make sure the mesh drum heads are not too loose.

Tighten up the tuning bolts evenly with tuning key, if needed.

- \* The mesh drum head is a consumable item. Replace when it has worn.

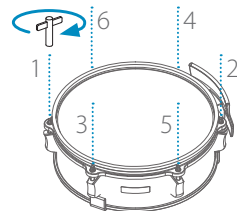

# Connection

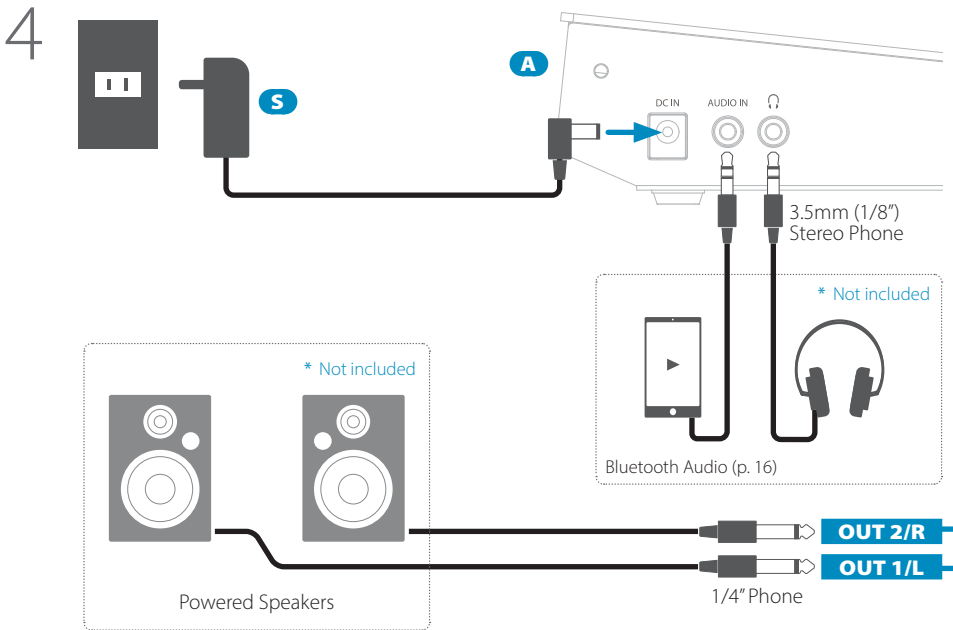
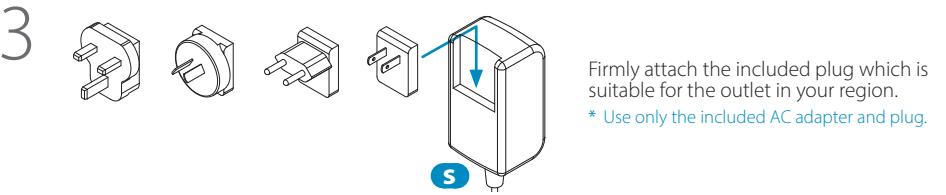
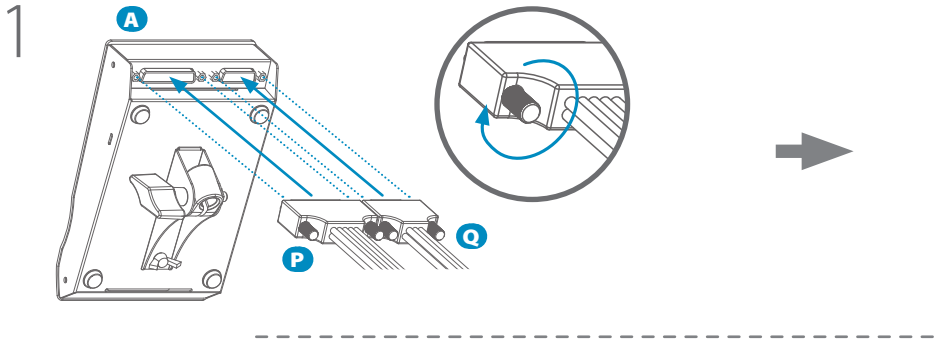

\* Audio cables are not included.

**MIDI OUT**

2

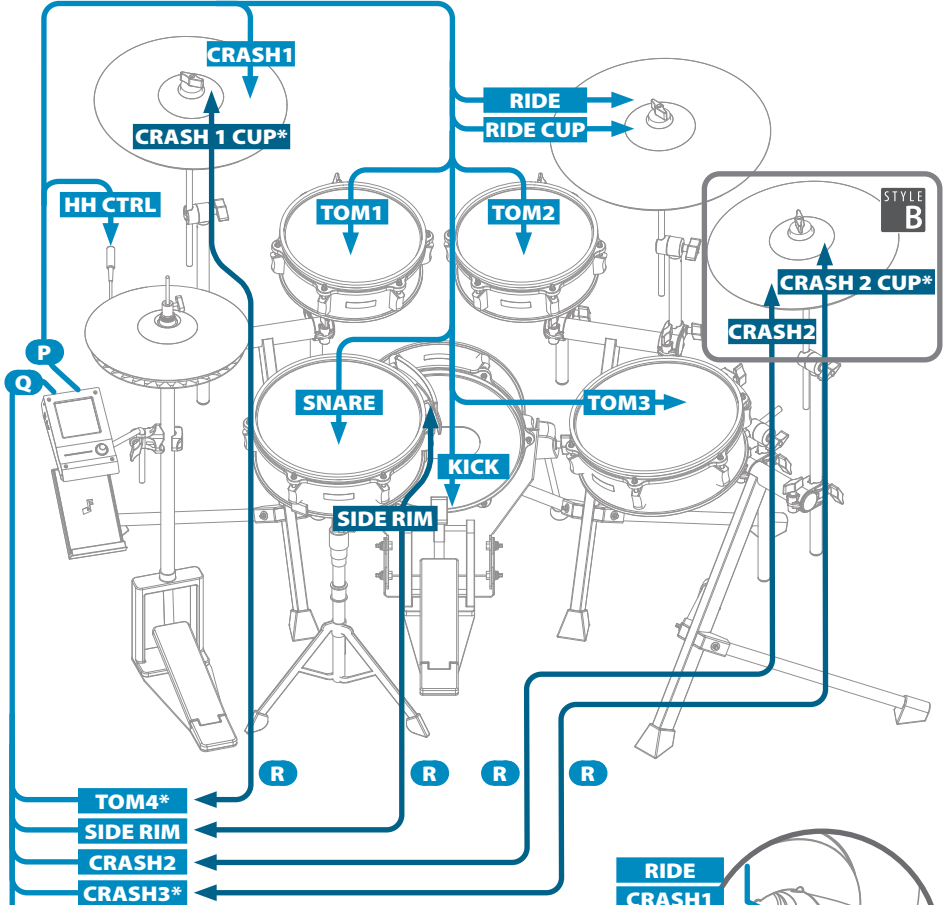

\* The TOM 4 and CRASH 3 cables can be used for the Crash 1 and Crash 2 Cups as shown in the figure above.

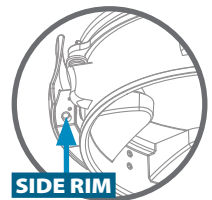
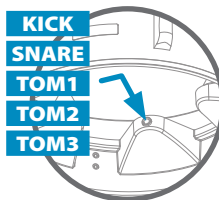
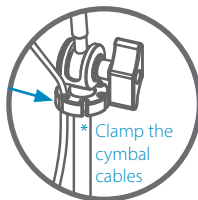
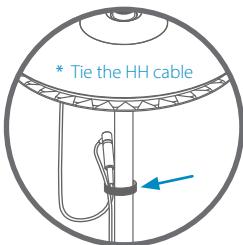
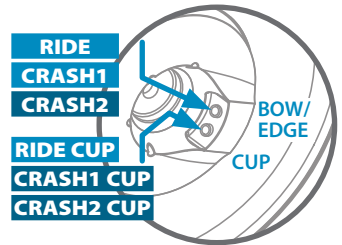

# Basic Operation

## ■ Panel Description

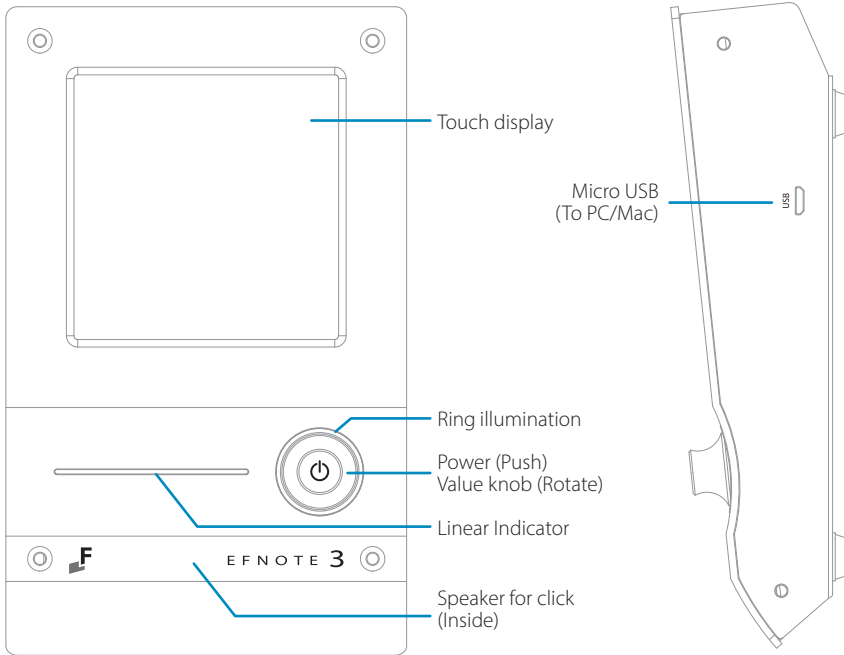

## ■ Power On/Off

### Power On

1

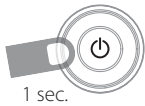

2



### NOTE

\* After turning the power on, adjust the hi-hat before playing the drums to get the best playing feel (p. 15).

### Power Off

1



2

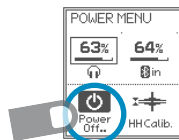

3

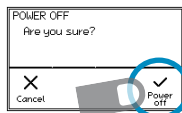

4



\* Not doing this procedure may result in loss of changes.

\* The power save function will turn power off automatically after specified period. It can be disabled (p. 15).

## Home Screen

### Switching drum kits

Shows the kit list

Previous drum kit < > Next drum kit

TAP TAP

Volume Info Click Record Menu

KIT

- 01: STUDIO F
- 02: Neo Classic
- 03: First Note
- 04: Beech
- 05: Unplugged
- 06: Speed Star
- 07: Recording
- 08: Hard Rock
- 09: Compact
- 10: Classic

Cancel Delete Duplicate OK

\* Actual kit names may vary.

## Volume

63% 64% 59% 72% X

Phones output level

Bluetooth audio in level

USB audio in level

Analog AUDIO IN level

## Inst Info

72% X

Level Instrument assigned to the pad

Pad level (Instrument level)

\* Clipping may occur when exceeding 85%.

## Click (Metronome)

Tempo (BPM)

Beat (Time signature)

Click level

Activates/deactivates external click speaker

126 4 52% X

Tempo Beat Level Ext Sp Close

Volume Info Click Record Menu

Turns click on/off

**CAUTION** Be sure not to listen to audio at a high volume. It can cause permanent hearing loss.

## Recorder

Records your drum performances by MIDI.  
\* Any other audio sources are not recorded.

2 Track Play Rec Clear Close

Selects target track

Plays target track

Goes to recording stand-by

Clears target track

### Rec Standby

01-1 Standby Stop Start Auto Rec Close

Status

Starts recording

Starts when strike

Cancels recording

### Recording

08-1 Recording Stop Close

Status

Stops recording

### Playing

06-2 Playing Stop FRev FFor Close

Status

Stops playing

Fast backward

Fast forward

## Menu



- Kit Edit: Edits drum kit
- Levels: Shows the pad level faders (p. 17)
- Inst Library: Changes instrument on each pad (p. 17)
- Set List: Organizes drum kits for gigs  
Manages your user custom instruments



- Click Setup: Configures click setup
- Stroke Scope: Displays your strike points on timeline
- Accuracy Score: Estimates your strike accuracy
- Rhythm Box: Provides basic drum beats



- Volume: Shows the volume control
- Bluetooth: Connects Bluetooth device (p. 16)
- Trigger: Configures triggers (pads)
- Settings: Configures general settings
- Close: Closes menu

Detailed information about screens can be accessed from the menu, please refer to the "Reference Guide" PDF available on the web (p. 2).

## Power Menu

You can access the power menu anytime.

1



2

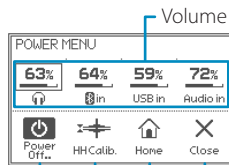

- Volume control: Volume control
- Power Off: Turns the power off
- HH Calib.: Goes to the hi-hat calibration screen
- Home: Goes back to Home screen
- Close: Closes menu

\* Push the knob again to close the menu.

## ■ Adjusting the Hi-Hat (Auto Calibration)

Adjusting the hi-hat brings the best hi-hat playing feel.

1



2

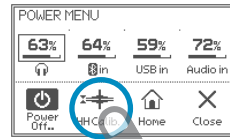

3

Drop the top hi-hat cymbal.

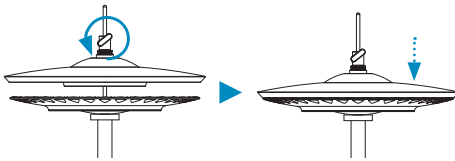

4

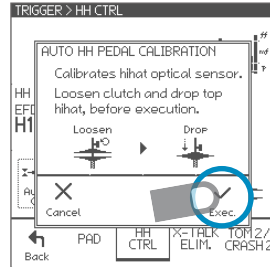

5

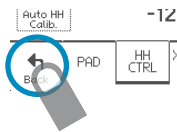

## ■ Changing the Power Save Setting

This will turn the power off automatically after a specified inactive period.

1



2

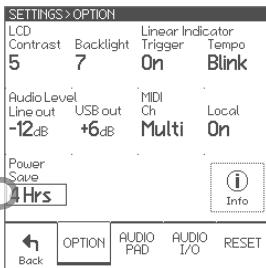

3



When OFF, the module will not turn off automatically.

## ■ Connecting Your Smartphone with Bluetooth

You can connect your smartphone to the EFNOTE 3 to listen to audio with Bluetooth.

### Connecting

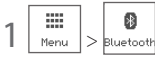

- 2 Make sure the status is "Ready to pair".  
If the status is "OFF", tap it to turn on.

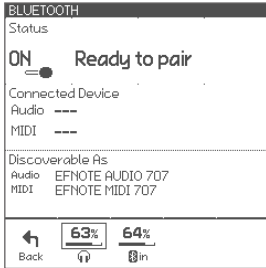

### On your smartphone

- 3 Turn Bluetooth on.
- 4 Find new device discoverable as "EFNOTE AUDIO xxx" (xxx is any value), and select it.
- 5 If pin code is required, enter "0000" (four zeros).
- 6 Tap [Pair].

- 7 Make sure the status changes to "Connected", and your phone's name is displayed.

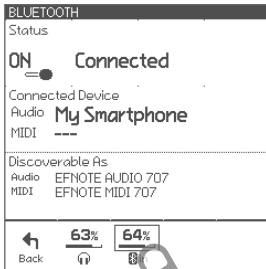

Controls Bluetooth input volume

- 8 Now, you can listen to the audio playing on your smartphone.

- \* The sound may be loud, so please be careful with the volume setting.
- \* If you can't hear the sound, make sure your smartphone's volume is turned up.

**CAUTION** Be sure not to listen to audio at high volume. It can cause permanent hearing loss.

### Disconnecting

- 1 Tap [Disconnect] on your smartphone.

### Re-connecting

- 1 Tap [Connect] on your smartphone.



## ■ Changing the Instrument



2 Hit the pad you want to change its instrument.

3

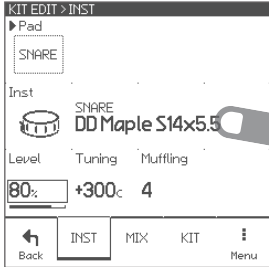

4

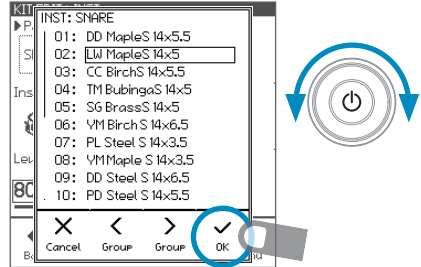

\* Actual instrument names may vary.

Instrument level, tuning (pitch), and muffling can be edited on this screen as well. For the other edit parameters, see the reference guide (p. 2).

\* Changes are saved automatically.

## ■ Adjusting the Pad Levels



2 Choose a pad.

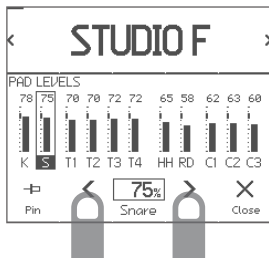

3 Adjust the level.

\* Clipping may occur when exceeding 85%.



\* You can also choose the pad by hitting it.

\* If pinned, the selected pad cannot be changed by hit.

\* Changes are saved automatically.

# Specifications

## Electronic Drum Kit: EFNOTE 3 (EFD3A-STDSET / EFD3B-STDSET)

Sound Module: EFD-3A

Item	Specifications
Trigger Interface	<ul style="list-style-type: none"> <li>• 3-Zone: SNARE, CRASH 1/2*, RIDE</li> <li>• 2-Zone: TOM 1/2/3/4, HI-HAT, CRASH 3</li> <li>• 1-Zone: KICK</li> </ul> <p>* CRASH 1 and CRASH 2 inputs support 3-zone triggering with using the TOM 4/CRASH 3 cables.</p>
Audio / MIDI Interface	<ul style="list-style-type: none"> <li>• Line (1/2) Output: 2x 1/4" TS Phone (+4dBu, Unbalanced)</li> <li>• Phones (3/4) Output: 3.5mm (1/8") Stereo Phone (320 mW + 320 mW @32Ω)</li> <li>• Audio Input: 3.5mm (1/8") Stereo Phone (+2dBu Max)</li> <li>• USB: Micro-B USB 2.0 Hi-Speed, Audio/MIDI USB Audio: 8-ch Output (48kHz/24bit) / 2-ch Input (48kHz/16bit), Mac/Windows ASIO</li> <li>• Bluetooth: Audio Input (A2DP), MIDI In/Out (Bluetooth Low Energy/GATT) Transmission Frequency: 2402--2480 MHz, Maximum Transmit Power: 2.5 mW EIRP</li> <li>• MIDI Out: 5-pin DIN</li> </ul>
Recorder	<ul style="list-style-type: none"> <li>• Resolution: 480 TPQN</li> <li>• Tracks: 5</li> <li>• Capacity: Approx. 8,000 Events/Track</li> </ul>
Power supply	DC 12V, 500 mA (Nominal) / 800 mA (Max)
Dimensions / Weight	172 (W) x 106 (D) x 47 (H) mm / 700 g * Excluding protrusions

### Pads and accessories

Item	Specifications
Kick (EFD-K12P)	<ul style="list-style-type: none"> <li>• Size: 12 x 4"</li> <li>• Zone: Head</li> <li>• Sensor: Multi</li> <li>• Connector: Head (1/4" TRS Phone)</li> </ul>
Snare (EFD-S12P)	<ul style="list-style-type: none"> <li>• Size: 12 x 4"</li> <li>• Zone: Head / Rim / Side-Rim</li> <li>• Sensor: Multi</li> <li>• Connector: Head/Rim, Side-Rim (2x 1/4" TRS Phone)</li> </ul>
Tom 1/2 (EFD-T10P) Tom 3 (EFD-T12P)	<ul style="list-style-type: none"> <li>• Size: 10 x 3.5" (Tom 1/2), 12 x 4" (Tom 3)</li> <li>• Zone: Head / Rim</li> <li>• Sensor: Multi</li> <li>• Connector: Head/Rim (1/4" TRS Phone)</li> </ul>
Hi-Hat (EFD-H12)	<ul style="list-style-type: none"> <li>• Size: 12" (Top/Bottom)</li> <li>• Zone: Bow / Edge / Cup</li> <li>• Pad Sensor: Multi (360° flat sensing + choke)</li> <li>• Motion Sensor: Multi Optical</li> <li>• Connector: 6-pin</li> </ul> <p>* EFNOTE 3 sound module does not support the hi-hat cup zone.</p>
Crash 1 (EFD-C14) Ride (EFD-C16)	<ul style="list-style-type: none"> <li>• Size: 14" (Crash 1/2), 16" (Ride)</li> <li>• Zone: Bow / Edge / Cup</li> </ul>
Crash 2 (EFD-C14)	<ul style="list-style-type: none"> <li>• Sensor: Multi (360° flat sensing + choke)</li> <li>• Connector: Bow/Edge, Cup (2x 1/4" TRS Phone)</li> </ul>
Accessories	<p>Multi Cable (EFD-MULTI-AX), Multi Cable (EFD-MULTI-B), 4x Trigger Cable 3.0 m (EFD-TRS-LL3), 3x Lambda Tripod, Snare Stand, Module Mount, Beater Patch, Smartphone Tray, AC Adapter, Cable Ties, Tuning Key, Quickstart Guide</p> <p>* Kick pedal, hi-hat stand, and drum throne are not included. * USB cable is not included.</p>

\* Specification and design are subject to change without prior notice.

\*  Tom 4, Crash 2, and Crash 3 pads are not included.

\*  Tom 4 and Crash 3 pads are not included.

## Optional components and consumable parts

Option	Item	Description
Adding a Crash 2 cymbal 	EFD-C14	Standard Cymbal 14" * Using the CRASH 2 cable. * The cup zone is available by using the CRASH 3 cable.
	EFD-CM3	Cymbal Mount
Adding a Tom 4	EFD-T12P-WS	Tom Pad 12" (White Sparkle) * Using the TOM 4 cable. * Change the trigger assign from CRASH 1 CUP to TOM 4.
	EFD-TM3	Tom Mount
Adding a splash cymbal (Crash 3)	EFD-C08	Splash Cymbal 8" * Using the CRASH 3 cable. * Change the trigger assign from CRASH 2 CUP to CRASH 3.
	EFD-SCM5	Splash Cymbal Mount
Replacing the drum head	EFD-MDH10	Mesh Drum Head 10"
	EFD-MDH12	Mesh Drum Head 12"
Replacing the beater patch	EFD-KBP2	Kick Beater Patch

\* When any optional pad is added, configure the Pad model and Assign in the Trigger screen. See the Reference Guide for the details.

\* Note that multiple options which use the same cable cannot be applied.

### Expanding Example

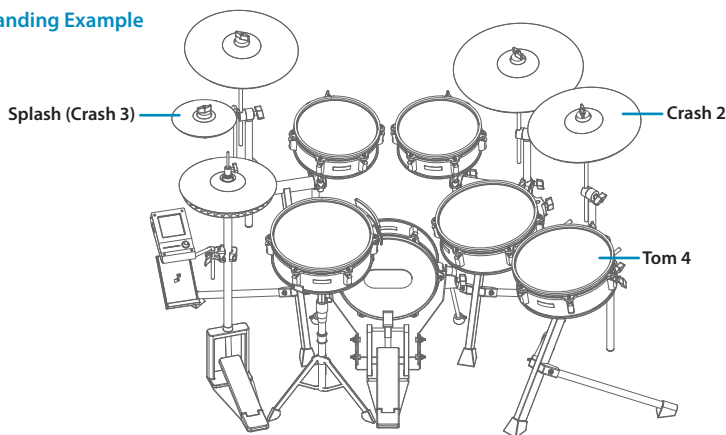

## Support

If you have any questions about the product, please visit the product support page on the web. Alternatively, please contact your local authorized distributor listed on the web below.

### Product Support

<http://ef-note.com/support>

### EFNOTE Authorized Distributor List

<http://ef-note.com/distributors>



Product Support



Distributors

**E F N O T E**

[ef-note.com](https://ef-note.com)